

SBG. . . SL
SBG. . . SLL

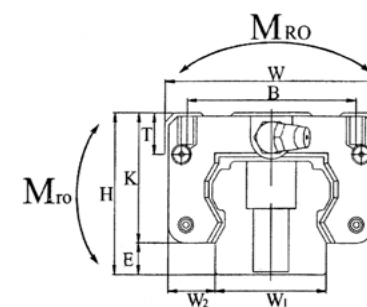

SBG. . . SL(SLL)

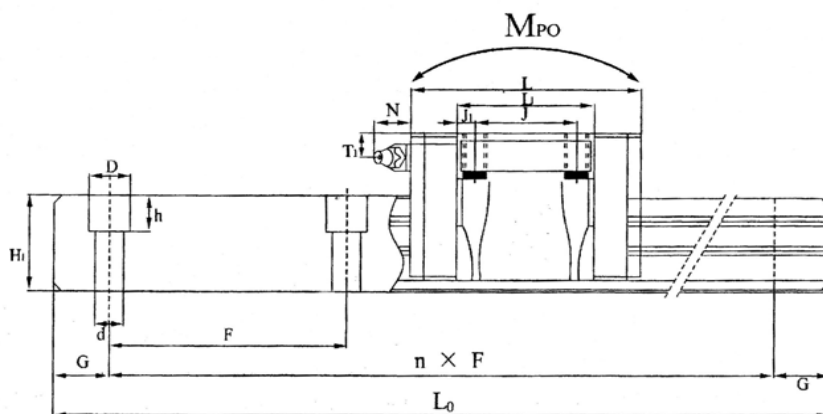

呼び番号 Type No.	主要寸法 (mm) Dimentions				ブロック寸法 (mm) Block Dimentions										レール寸法 (mm) Rail Dimentions					基本定格荷重(kgf)		静的許容モーメント			重量 Weight		
	H	E	W2	W	L	取付け寸法 B×J M×L		L1	J1	K	T	グリスニップル 穴径 T1 N		W1	H1	F	ボルト d×D×h G Lo (最大)		動荷重 C (Dyn)	静荷重 Co (Sta)	MRO	kgf. M MPO MrO		ブロック kgf	レール kgf/M		
SBG15SL	28	3.0	9.50	34	56.5	26×26	M4×5	38.8	6.4	25.0	6.0	3	8.25	5.5	15.0	15.0	60	4.5×7.5×5.3	20	1600	840	1370	7	5	5	0.14	1.50
SBG20SL	30	3.6	12.0	44	74.0	32×36	M5×6	50.8	7.4	26.5	8.0	M6×0.75	4.45	12	20.0	17.5	60	6×9.5×8.5	"	3040	1400	2420	22	18	18	0.26	2.16
SBG20SLL			90.0		66.8			8.4	2170												3240	31	35	35	0.40		
SBG25SL	40	5.2	12.5	48	83.0	35×35	M6×8	59.5	12.25	35.5	8.0	"	9.95	"	23.0	21.8	60	7×11×9	"	4480	2020	3500	36	32	31	0.44	3.14
SBG25SLL			102.5		78.6			14.30	2770												4680	48	54	53	0.80		
SBG30SL	45	5.5	16.0	60	98.0	40×40	M8×10	70.4	15.20	39.5	8.0	"	11.5	"	28.0	25.0	80	9×14×12	"	4440	2360	3970	50	36	36	0.72	4.50
SBG30SLL			120.5		93.0			16.50	3800												6375	80	86	85	1.20		
SBG35SL	55	7.5	18.0	70	109.5	50×50	M8×12	80.4	15.20	47.5	10.0	"	16.5	"	34.0	29.0	80	9×14×12	"	4440	3800	6230	96	75	73	1.14	6.30
SBG35SLL			135.0		105.8			16.90	5120												8310	136	144	141	2.00		
SBG45SL	70	8.0	20.5	86	139.0	60×60	M10×17	98.0	19.00	62.0	15.0	PT1/8	20.5	16	45.0	38.0	105	14×20×17	22.5	4450	6120	9750	216	170	168	2.0	10.9
SBG45SLL			171.0		129.8			24.90	8200												12954	264	251	248	3.8		
SBG55SL	80	10.5	23.5	100	163.0	75×75	M12×18	118.0	21.50	69.5	18.0	"	22.0	"	53.0	45.0	120	16×23×20	30.0	4480	9020	13970	367	293	288	4.2	14.9
SBG55SLL			201.0		156.1			30.55	12130												18660	449	435	426	6.0		
SBG65SL	90	17.5	31.5	126	186.0	76×70	M16×20	147.0	38.50	72.5	23.0	"	15.0	"	63.0	58.5	150	18×26×22	35.0	4390	14380	21900	629	495	484	6.15	21.3
SBG65SLL			246.0		206.5			43.25	19580												29170	834	850	830	10.5		

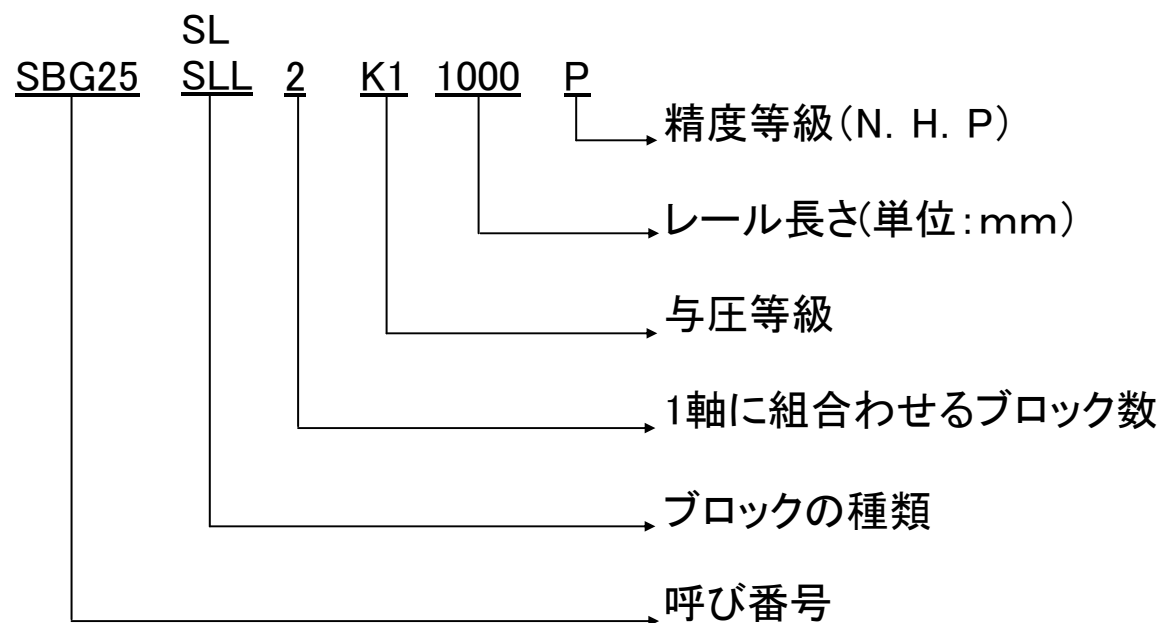

SBG. . . FL
SBG. . . FLL



SBG. . . FL(FLL)

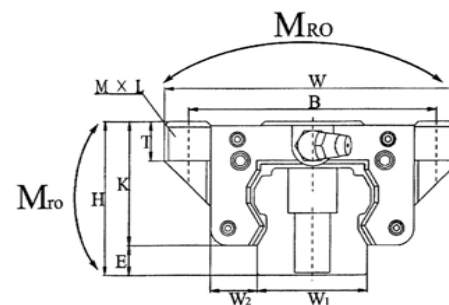
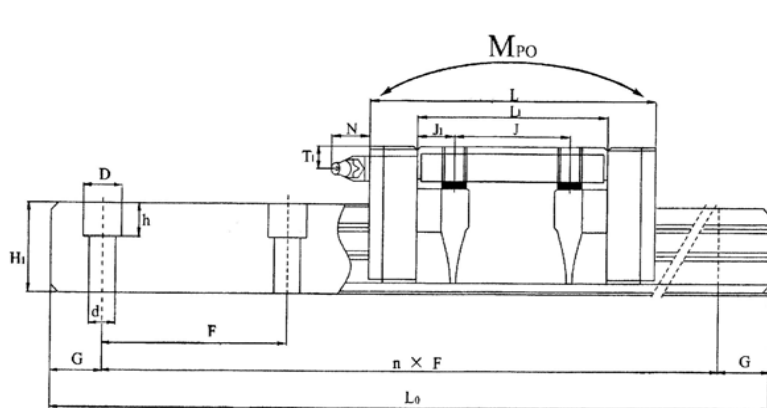

呼び番号 Type No.	主要寸法 (mm) Dimensions				ブロック寸法 (mm) Block Dimensions										レール寸法 (mm) Rail Dimensions					基本定格荷重(kgf)		静的許容モーメント			重量 Weight		
	H	E	W2	W	L	取付け寸法 B x J M x L		L1	J1	K	T	グリスニップル 穴径 T1 N		W1	H1	F	ボルト d x D x h G		Lo (最大)	動荷重 C (Dyn)	静荷重 Co (Sta)	kgf. M			ブロック kgf	レール kgf/M	
SBG15FL	24	3.0	16.0	47	56.5	38 x 30	M5 x 11	38.8	4.4	21.0	7.2	3	4.25	5.5	15.0	15.0	60	4.5 x 7.5 x 5.3 20		1600	850	1370	7	5	5	0.12	1.50
SBG20FL	30	3.6	21.5	63	74.0	53 x 40	M6 x 10	50.8	5.4	26.5	9.0	M6 x 0.75	4.45	12	20.0	17.5	60	6 x 9.5 x 8.5 "		3040	1400	2420	22	18	18	0.30	2.16
SBG20FLL					90.0			66.8													13.4	2170	3240	31	35	35	
SBG25FL	36	5.2	23.5	70	83.0	57 x 45	M8 x 16	59.5	7.25	31.5	10	"	5.95	"	23.0	21.8	60	7 x 11 x 9 "		4480	2030	3500	36	32	31	0.46	3.14
SBG25FLL					102.5			78.6	16.80												2770	4680	48	54	53	0.81	
SBG30FL	42	5.5	31.0	90	98.0	72 x 52	M10 x 18	70.4	9.60	36.5	12	"	8.5	"	28.0	25.0	80	9 x 14 x 12 "		4440	2855	4770	50	36	36	0.82	4.50
SBG30FLL					120.5			93.0	20.50												3800	6370	80	86	85	1.40	
SBG35FL	48	7.5	33.0	100	109.5	82 x 62	M10 x 20	80.4	9.20	40.5	13	"	9.5	"	34.0	29.0	80	9 x 14 x 12 "		4440	3800	6230	96	75	75	1.22	6.30
SBG35FLL					135.0			105.8	21.90												5120	8310	136	144	141	2.10	
SBG45FL	60	8.0	37.5	120	139.0	100 x 80	M12 x 24	98.0	9.00	52.0	15	PT1/8	10.5	16	45.0	38.0	105	14 x 20 x 17 22.5		4450	6120	9750	216	170	168	2.02	10.9
SBG45FLL					171.0			129.8	24.90												8200	12950	264	251	248	3.80	
SBG55FL	70	10.5	43.5	140	163.0	116 x 95	M14 x 28	118.0	11.50	59.5	17	"	12.0	"	53.0	45.0	120	16 x 23 x 20 30.0		4480	9020	13970	367	293	288	4.50	14.9
SBG55FLL					201.0			156.1	30.55												12100	18660	449	435	426	6.30	
SBG65FL	90	17.5	53.5	170	186.0	142 x 110	M16 x 24	147.0	18.50	72.5	23	"	15.0	"	63.0	58.5	150	18 x 26 x 22 35.0		4390	14380	21900	629	493	484	6.24	21.3
SBG65FLL					246.0			206.5	48.25												19580	29170	834	850	830	14.0	

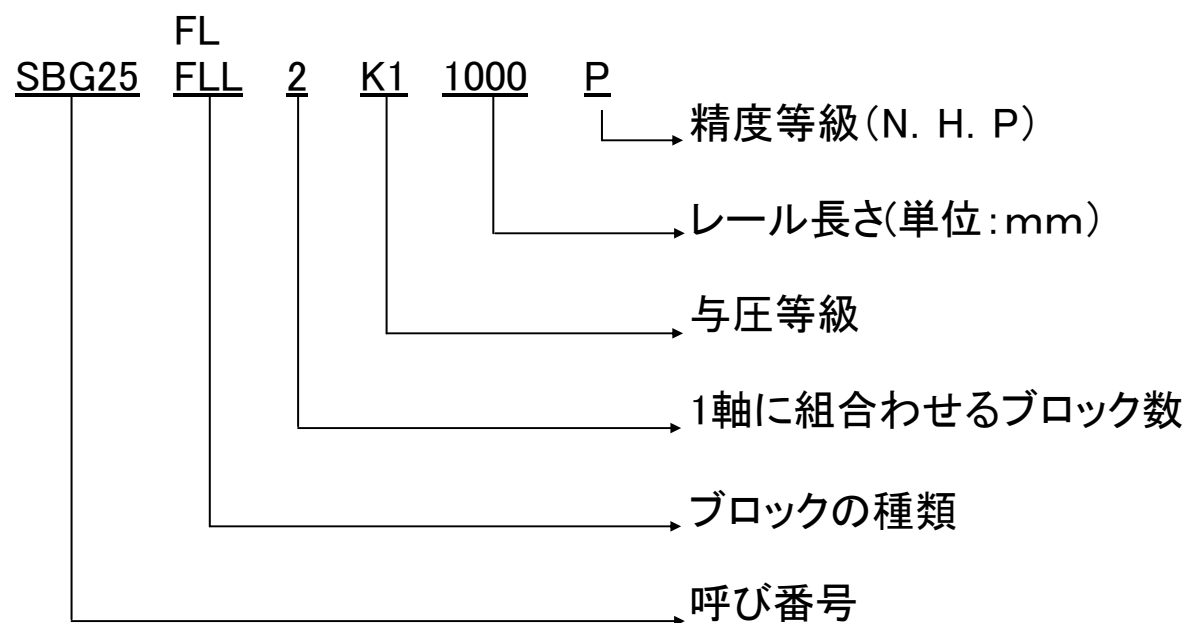

MGW...C
MGW...H



MGW...C(H)

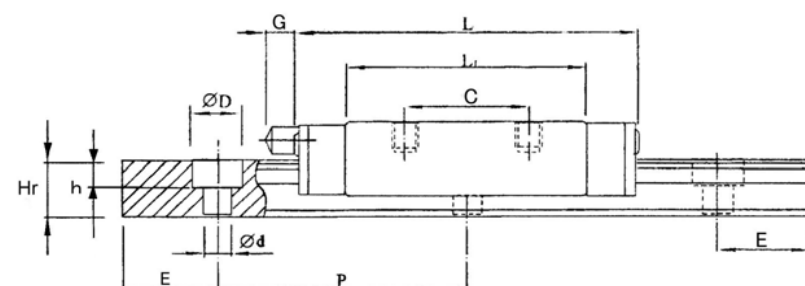

MGW12C(H)

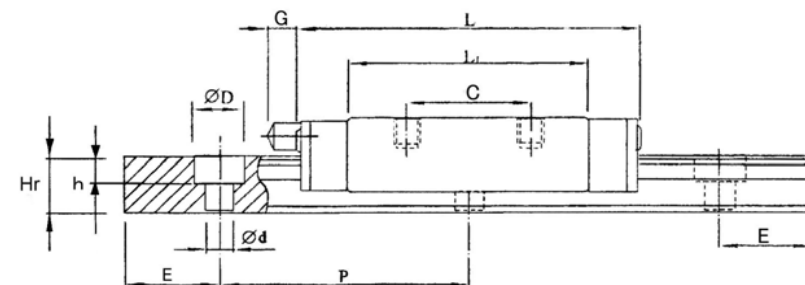

MGW15C(H)

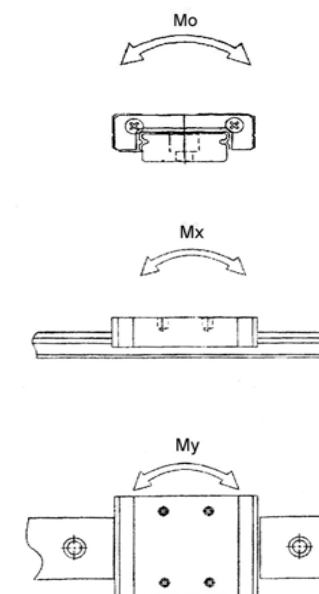
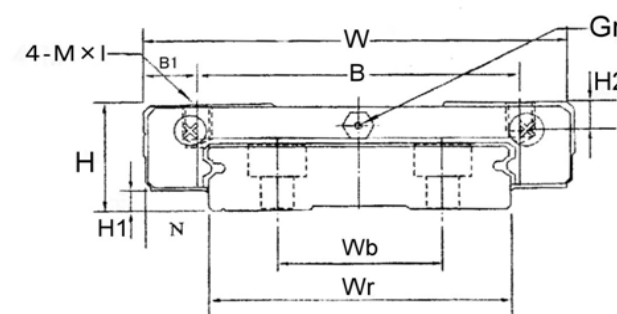
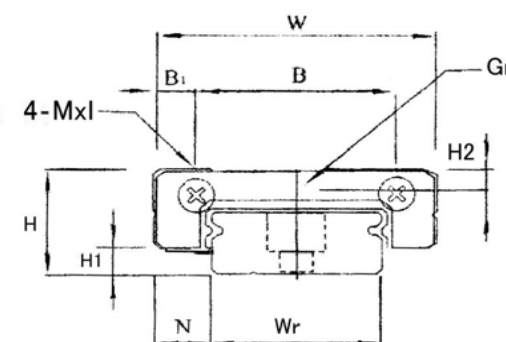

呼び番号 Type No.	主要寸法 (mm) Dimensions			ブロック寸法 (mm) Block Dimensions										レール寸法 (mm) Rail Dimensions						取付け ねじ	基本定格荷重 (kgf)		静的許容モーメント			重量 Weight			
	H	H1	N	B	B1	C	L1	L	Mxl	W	グリスニップル G	Gn	H2	Wr	Wb	Hr	D	h	d		P	E	動荷重 C (Dyn)	静荷重 Co (Sta)	Mo	Mx	MY	ブロック kg	レール kg/m
MGW7C MGW7H	9	1.9	5.5	19	3.0	10	21.0	31.2	M3x3	25	-	φ0.9	1.85	14	-	5.2	6	3.2	3.5	30	10	M3x6	140	210	1.60	0.73	0.73	20.0	0.51
MGW9C MGW9H	12	2.9	6.0	21	4.5	12	27.5	39.3	"	30	-	φ1.0	2.40	18	-	7.0	"	4.5	"	"	"	M3x8	280	420	4.09	1.93	1.93	40.0	0.91
MGW12C MGW12H	14	3.4	8.0	28	6.0	15	31.3	46.1	M3x3.6	40	-	φ1.0	2.80	24	-	8.5	8	"	4.5	40	15	M4x8	400	570	7.170	2.83	2.83	71.0	1.49
MGW15C MGW15H	16	"	9.0	45	7.5	20	38.0	54.8	M4x4.2	60	5.2	GN3S	3.20	42	23	9.5	"	"	"	"	"	M4x10	690	940	20.32	5.78	5.78	143	2.86
						35	57.0	73.8															910	1410	30.48	12.5	12.5	215	